

FUNCTIONAL SCHEMATIC

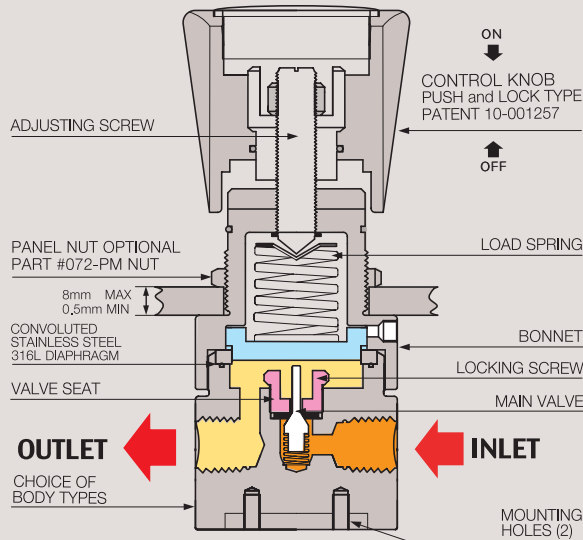

FLOW CHART

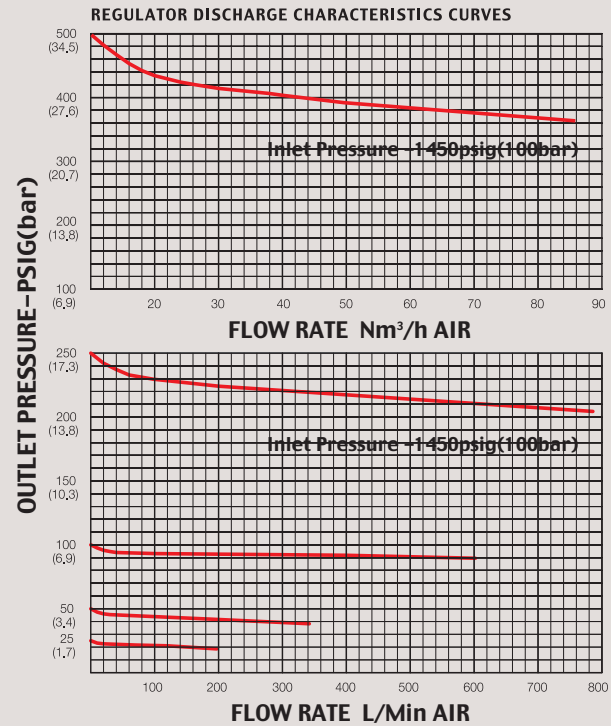

GAS AND LIQUID PRESSURE REDUCING REGULATOR

072 SERIES

072시리즈는 정밀 산업에서 가장 많이 필요로 하고 가장 많이 사용되는 1/4" NPT type Pressure Reducing Regulator입니다. 본체와 내부의 모든 부품은 Stainless steel 316L로 이루어졌으며, Bulk Gas Line, 실험실, 분석용 특수 가스, 또는 고순도 가스, 미싱용 가스, 그리고 부식성 기체와 액체 등에서 모두 사용할 수 있도록 제작 설계되었습니다. 사용 용도에 따라 3-ports 또는 4-ports를 선택하여 사용할 수 있도록 하였습니다. 입구 압력은 3500psig(241bar)이고 Outlet working pressure 각각의 모델에 따라 최대 500psig(35bar)까지 사용할 수 있습니다. 모든 DRASTAR Regulators는 외부적인 진동과 가스배관 라인의 미세 진동 등으로 인하여 초기 셋팅 값이 스스로 변하는 현상을 완전히 해결한 드라스타만의 Push and Lock 타입의 조절 손잡이를 적용하여 사용하기에 더욱 편리합니다. 조절 손잡이를 누르면 셋팅값의 변하는 것을 방지하며, 손잡이를 앞으로 당기면 자유롭게 원하는 압력으로 다시 셋팅 할 수 있는 드라스타만의 특허 10-2009-0012957출원한 Push and Lock 타입의 레귤레이터입니다.

072 Series gas regulators are specially designed to regulate the high-corrosive gas and liquid and suitable for semi-conductor equipment production line where the special gases are used and liquid line. As the product's body and all internal parts are made of stainless steel 316L 072S Series, they can be also used for ultra-pure six-nine(99.9999) gases. 3-ports or 4-ports 1/4" FNPT can be connected to this 072S Series. DRASTAR regulators are designed and manufactured for easier operation by equipping with the DRASTAR's own developed push and lock type handle which completely prevents the self-change of pre-set value which can be caused by the vibration from outside or minute vibration

SPECIFICATIONS

Ports	1/4" NPT type 072X-0000L-1S, 3-ports 072X-0000C-1S, 4-ports
Leak Rate Certification	to 2x10 ⁻⁸ atm cc/sec Helium available.
Body Materials	072S-0000-1S / Stainless steel 316L 072B-0000-1S / Brass
Bonnet Material	Nickel Plated Brass / Stainless steel 316L
Diaphragm	Stainless steel 316L
Main Valve	Stainless steel 316L
Valve Spring	Stainless steel 316L
Valve Seat	Teflon® (Kel-F, Polyimide, etc.. Optional)
Inlet Pressure Ranges	072X-0000-1S, 3,500psig (238bar) 072X-0000-1S-5, 500psig (35bar)
Outlet Pressure Ranges	25(1.7bar), 50(3.4bar), 100(7bar), 250(17bar), 500psig(35bar)
Self-Venting	072X-0000-1S-V, Optional
Operating Temperature	-40°C - +70°C (-40°F - +160°F) (standard) 072x-0000-1S-H1, +120°C (Optional) 072x-0000-1S-H2, +250°C (Optional)
Flow Capacity	Cv=0.06 (Cv=0.2 etc.. Optional)
Standard Optional	CGA, Inlet and Outlet Gauges, etc..

REFERENCE

This catalogue is printed as of January 2010, and the dimensions and/or specifications in this catalogue can be changed without prior notice in the course of constant upgrading and improvement of our products.

INSTALLATION DIMENSIONS
METRIC EQUIVALENTS ARE IN PARENTHESES

■ GAUGE PORT OPTIONS

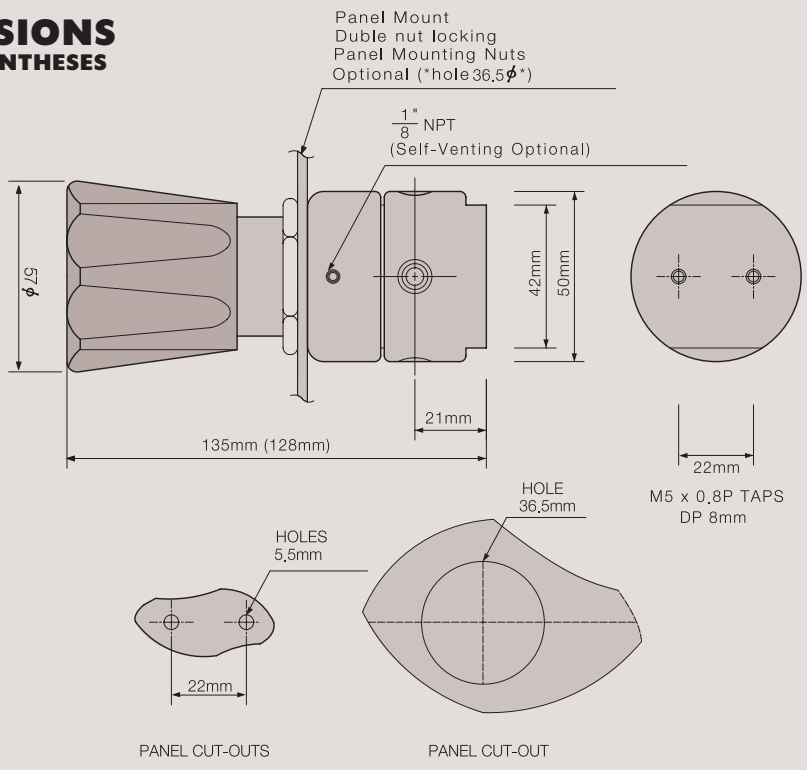
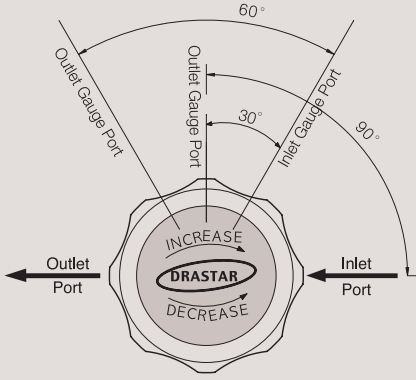

at the gas pipeline. You can prevent the self-changing of pre-set value just by pushing the handle and reset the value freely by drawing the handle. DRASTAR has created and applied patent for this push and lock system for DRASTAR regulators (patent number 10-2009-0012957).

Features

- Precision control of 1/4" NPT type Regulator
- Suitable for the research labs, industrial control
- Inlet 3500 or 500 psig
- Outlet 25psig(1.7bar), 50psig(3.5bar), 100psig(7bar), 250psig(17bar),500psig(35bar)
- Panel mounting nut option
- W072S-0000x-10 / W MODEL IS ONLY TYPE for LIQUID or WATER

관장 사항

각 제품들은 최고의 안전성과 쉬운 조작성을 고려하여 제작되었습니다. 그러나 가장 안전하고 효율적인 Regulator 사용을 위해서는 실제 사용 압력을 각각 모델의 사용 압력에 25% ~ 75% 이내에서 사용하면 가장 이상적인 압력을 사용할 수 있습니다. 정밀하고 원활한 동작과 제품의 수명 연장을 위해서는 위의 범위 내에서 사용하기를 적극 권장합니다.

Recommendations

Each product is manufactured since being taken into consideration of the best safety and easy manipulation. However in order to use the regulator in most safe and effective way, you are recommended to use the actual pressure within the range of its 25% ~ 75%. For making precise, smooth movement and to prolong product life, strongly recommended to make a use within above mentioned range.

ORDERING INFORMATION

W 072 S - 0025 L - 1 S - H - 5 - V - H1

- W MODEL IS ONLY TYPE FOR LIQUID or WATER**
- BASIC SERIES NUMBER**
Standard Inlet Pressure
3500PSIG (238 bar)
- BODY MATERIAL**
B = Brass
S = Stainless Steel 316L
- OUTLET PRESSURE RANGE**
0025 = 1-25PSIG (.1~1.7 bar)
0050 = 1-50PSIG (.1~3.5 bar)
0100 = 1-100PSIG (.1~ 7 bar)
0250 = 2-250PSIG (.1~17 bar)
0500 = 3-500PSIG (.2~35 bar)
- PORT TYPE**
L = 3-ports
C = 4-ports

- HIGH TEMPERATURE OPTION**
H1 = 120°C H2 = 250°C
- V = Self-Venting (Optional)
- INLET PRESSURE OPTION**
5 = 500psig (35 bar)
- DIAPHRAGM MATERIAL**
H= Hastelloy-c(Optional)
- FLOW CAPACITY**
S = Cv=0.06 (Standard)
0 = Cv=0.2, etc...
- INLET AND OUTLET PORTS SIZE**
1 = 1/4" NPT

072 SERIES PART LIST

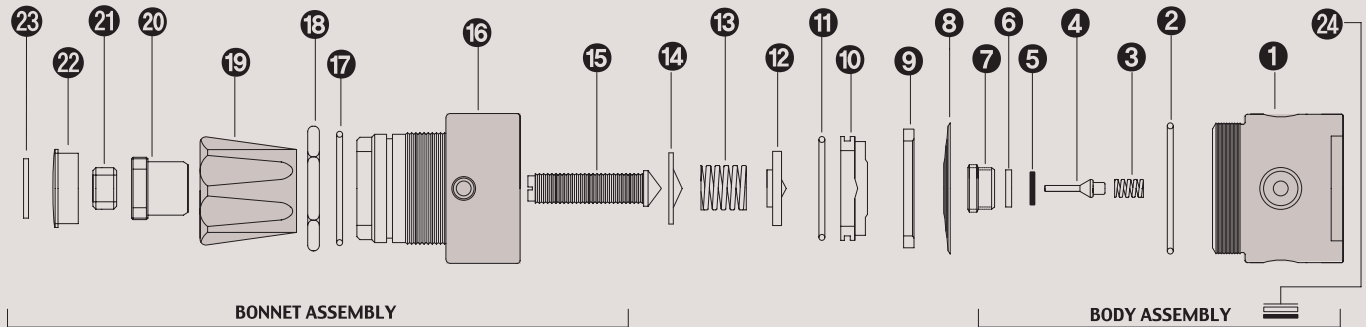

STANDARD MODEL SERIES

Item No.	Description	Part No.	Model Application
01	Body	072-02-01	02-01 Stainless Steel 316L body / 02-02 Brass body
02	Boby O-Ring	072-02-00	All Model Same
03	Valve Spring	072-04-01	04-01 STS 316L / 04-03 Hastelloy-C-22 / 04-04 Monel
04	Main Valve	072-06-01	06-01 STS 316L / 06-03 Hastelloy-C-22 / 06-04 Monel
05	Valve Seat	072-10-01	10-01 PFA / 10-05 Vespel / 10-06 Peek
06	Valve Seat Cartridge	072-08-01	08-01 Stainless Steel 316L / 08-02 Brass
07	Locking Screw	072-12-01	All Model Same
08	Diaphragm	072-16-01	16-01 STS 316L / 16-02 Hastelloy C-22
09	Diaphragm Plate	072-22-02	All Model Same
10	Back-up Plate	072-26-03	All Model Same
11	Back-up Plate O-Ring	072-28-01	All Model Same
12	Spring Plate	072-30-01	All Model Same
13	Load Spring	072-38-01	11-01 25psi / 11-02 50psi / 11-03 100psi / 11-05 250psi / 11-07 500psi
14	Pivot	072-40-01	All Model Same
15	Adjusting Screw	072-42-01	All Model Same
16	Bonnet	072-44-02	44-01 Stainless steel 316L / 44-02 Brass
17	Push & Lock O-Ring	072-46-01	All Model Same
18	Panel mount Nut	072-48-01	All Model Same
19	Control Knob	072-50-01	50-01 ABS / 50-04 Aluminum Control knob
20	Push & Lock Handle nut	072-52-01	All Model Same
21	Locking Nut	072-54-01	All Model Same
22	Name Cap	072-56-01	56-01 ABS
23	Name Cap Plate	072-58-01	58-01 25psi/58-02 50psi/58-03 100psi/58-04 200psi/58-06 350psi/58-07 500psi
24	Filter Assembly	072-60-01	All Model Same